

A series of thin, light blue lines that originate from the left side of the page and curve upwards and to the right, creating a sense of motion and technology. They are set against a dark blue background.

zeus **marking technology**

Revolving system

Spring-return system

Stamps



Signs of the time



Benefits and added value	3
General – revolving system	4
General – spring-return system	5
Applications	6
Overview table	7
<hr/>	
Revolving system	8
<hr/>	
Marking roll n° 40/n° 40-K	8
Marking tools 130/131/311/312	9
<hr/>	
Spring-return system	10
<hr/>	
Marking roll n° 41	10
Tool set 421	11
Marking roll n° 41	12
Tool set 422	13
Marking segment n° 42	14
Tool set 431	15
Marking segment n° 43	16
Tool set 432	17
<hr/>	
Engraving technology	18
<hr/>	
Technology	21
<hr/>	
Important information	21
Revolving system	22
Spring-return system	24
<hr/>	
Inquiry form	26
<hr/>	
Revolving system	26
Spring-return system	27

Benefits and added value

Why zeus?

zeus marking technology is:

Fast: Processing times are significantly shorter in comparison with other marking technologies such as laser marking, needle embossing, etc.

Affordable: With the complete machining on a single machine, equipping times are significantly reduced and/or minimised.

Flexible: Compatible with all conventional machines and CNC lathes and milling centres.

Features and benefits

- Improved quality of documentation
- Durability due to embossing
- Quality characteristic
- Component can be painted
- Elimination of separate work processes
- Immediate traceability
- Batch separation and tracking
- Complete production documentation
- Clear differentiation from the competition or no-name products
- Modern, just-in-time production requires absolute reliability
- Lateral drives can be removed after completion of the marking process
- Special characters can be used as a drive, e.g. logos, backslash, asterisks, number signs, etc.

Why mark?

In this day and age, marking of workpieces is absolutely indispensable for state-of-the-art production technologies with assemblies and system components. Immediate traceability, batch separation and tracking, as well as complete production documentation are essential requirements in many sectors.

But many types of marking for various applications are time-consuming, inflexible and therefore also cost-intensive.

With zeus marking technology, workpieces and turned parts of all types can be marked quickly, affordable and flexibly. The marking process is integrated directly in the machining process without changing to a separate machine.

As a result, there are no additional equipping costs – transport and storage times are eliminated.

And where is it used?



Automotive



Valves



Fittings



Machine construction



Aerospace



Hydraulics / pneumatics



Consumer goods



Decorative



Jewellery

Revolving system

The revolving system is particularly useful for large and mid-sized series and for **recurring components**.

The marking roll is custom-built and adapted to the diameter of each individual workpiece. Thanks to the user-friendly mount system, operators can exchange the rolls quickly and easily so that the tool can be used for a broad range of different workpieces and markings.

Features and benefits

- Fast and economical
- Marking rolls can be easily exchanged
- Easy handling
- The marking is dependent on the workpiece diameter
- A drive provides for perfect revolving application of the marking
- Multiple revolutions ensure perfect precision and definition of the impression
- Perfect concentricity of max. 0.03 mm is essential
- The workpiece diameter must be guaranteed within very close tolerances (± 0.025 mm)
- Lateral drives can be removed after completion of the marking process
- Marking on conical surfaces is possible

Marking rolls and tools



! for conical applications and flat faces



! for conical applications

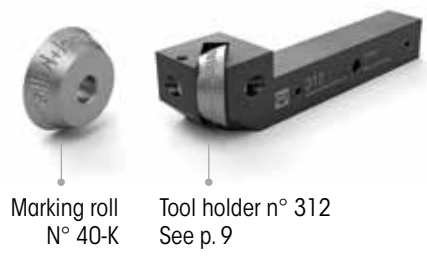

Spring-return system

The spring-return system offers a maximum of flexibility in all areas. You may use it for multiple workpieces with different diameters. Exchangeable marking segments facilitate economic text changes. The versatile spring-return system is designed for fast and easy exchange of the entire segment mount/marketing roll unit.

Features and benefits

- Suitable for marking of different workpiece diameters
- Flexible marking for different applications due to exchangeable text segments, such as consecutive batch numbers, serial numbers, manufacturing data, etc.
- When you need a different text, you can simply exchange the entire mount unit – quick and easy
- Possible to mark workpieces up to a shoulder
- Three driving points guarantee a perfect impression during the rotating process
- Marking without driving points is possible, as long as the C-axis can be controlled
- Marking is achieved by one-time partial revolution of the mount unit, which stops at the end of the text
- Desired depth can be achieved at fast speed

Marking rolls/ segments and tools



Applications

Where and how can workpieces be marked?

The example shows that you can mark at practically any position. Whether you require marking on spherical or conical surface, up to a shoulder, on end face or inner surface – zeus marking technology will satisfy your requirements.

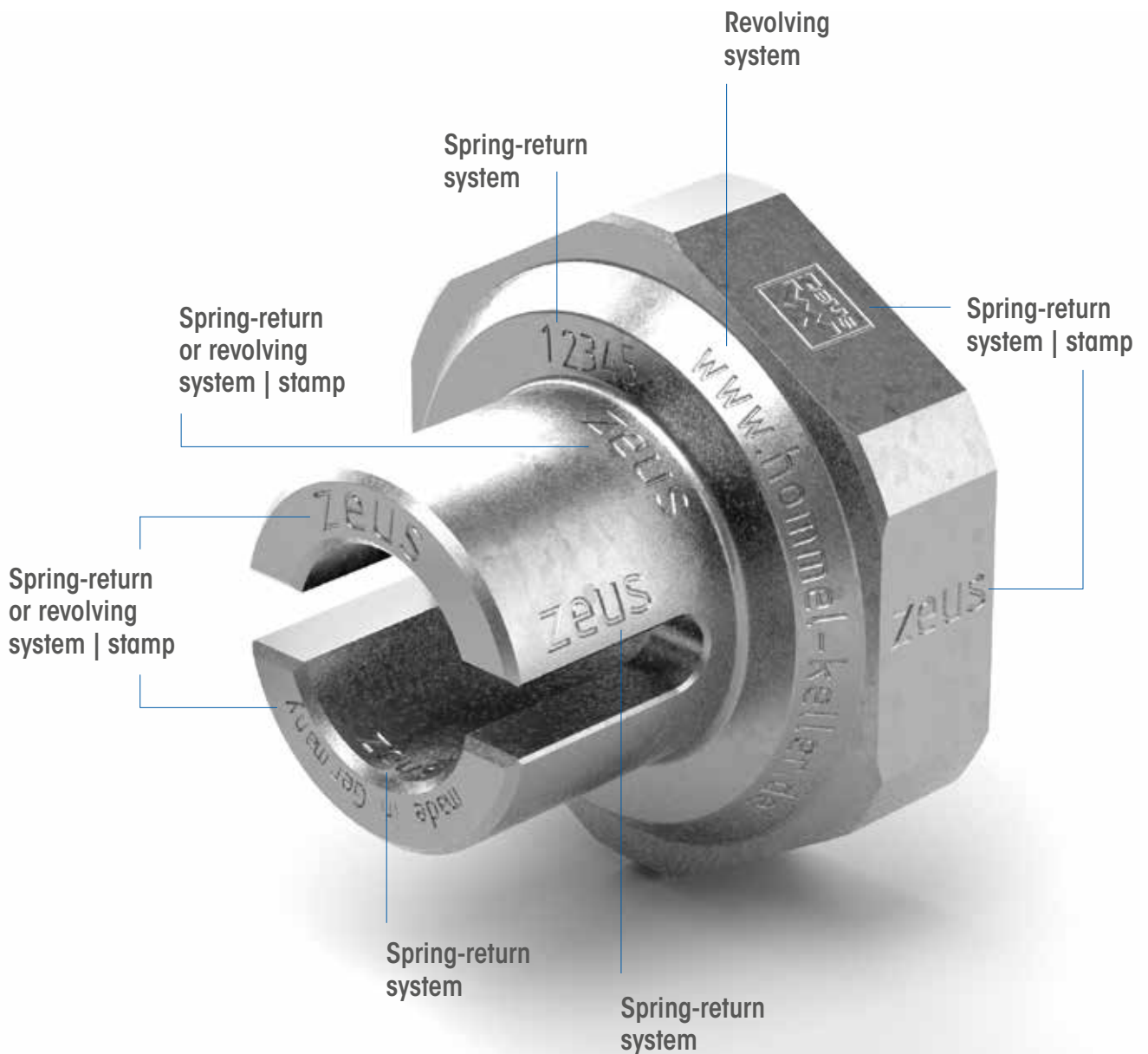

Revolving marking system – with marking roll

Tool n°	Marking roll n°	Marking on workpiece	Marking roll Ø [mm]	Marking roll width [mm]	Shank size [mm]	Adaptable to shank size	Integrated centre height	Marking up to a shoulder
130	40	Circumference	Application-specific	Application-specific	Machine-specific	–	–	–
131	40	Circumference	Application-specific	Application-specific	Machine-specific	–	■	–
311	40-K	End face/ Conical surface	Application-specific	Application-specific	Machine-specific	–	■	–
312	40-K	End face/ Conical surface	Application-specific	Application-specific	Machine-specific	–	■	–

Spring-return marking system – with marking roll

Tool n°	Marking roll n°	Marking on workpiece	Marking roll Ø [mm]	Marking roll width [mm]	Shank size [mm]	Adaptable to shank size	Integrated centre height	Marking up to a shoulder
421	41	Circumference/ End face/ Flat face	25	6	16	20/25	■	–
422	41	Circumference/ End face/ Flat face	15	5	8	10/12/16	■	–
422	41	Circumference/ End face/ Flat face	15	7	8	10/12/16	■	■

Spring-return marking system – with marking segments

Tool n°	Marking segment No.	Marking on workpiece	Marking segment Ø [mm]	Segment width [mm]	Shank size [mm]	Adaptable to shank size	Integrated centre height	Marking up to the collar
431	42	Circumference/ End face/ Flat face	45	6	16	20/25	■	–
432	43	Circumference/ End face/ Flat face	30	8	8	10/12/16	■	■
432	43	Circumference/ End face/ Flat face	50	8	16	20/25	■	■

Marking roll n° 40



Benefits

- Easy handling
- Fast and economical
- Suitable for series production
- Marking rolls can be easily exchanged
- All characters can be used as a drive, e.g. logos, backslash, asterisks, number signs, etc.

Features

- The design of marking roll n° 40 is dependent on the workpiece diameter
- A drive provides for perfect revolving application of the marking.
The lateral drives can be removed after marking

Product features		For marking tools
Flank angle	90°	130/131
Roll width [mm]	Application-specific	
Typeface	According to DIN 1451	
Additional details	See "Technology" starting on page 20	

Marking roll n° 40-K



Benefits

- Easy handling
- Fast and economical
- Suitable for series production
- Marking rolls can be easily exchanged
- All characters can be used as a drive, e.g. logos, backslash, asterisks, number signs, etc.

Features

- The design of marking roll n° 40-K is dependent on the pitch circle/markings diameter
- A drive provides for perfect revolving application of the marking

Product features		For marking tools
Flank angle	90°	311/312
Roll width [mm]	Application-specific	
Typeface	According to DIN 1451	
Additional details	See "Technology" starting on page 20	

Tool n° 130/131



Ideal for all markings, with impressive ease of use

The tool holders are custom designed for the marking roll for your application.

Product features

- Centre height must be adjusted (series 130)
- Top edge of shank = centre height (series 131)
- Set screws in shank for correcting alignment
- Carbide pin

Tool n° 311/312



Ideal for marking applications on conical surfaces and flat faces

Examples of applications for tool n° 311

- **Marking on flat faces**
When applying the marking to a flat face, the calculated position of the pitch circle diameter must be taken into account

Product features

- Top edge of shank = centre height
- Set screws in shank for correcting alignment
- Carbide bolts (series 311)
- Carbide pin (series 312)

- **Marking conical surfaces**
You must match the pitch circle diameter of the marking roll to the desired position on the workpiece

Examples of applications for tool n° 312

- **Marking conical surfaces**
You must match the pitch circle diameter of the marking roll to the desired position on the workpiece

The tool holders are custom designed for the marking roll for your application.

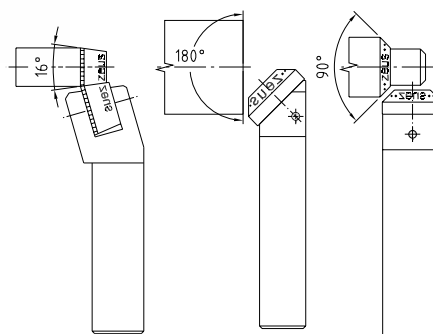

Marking roll n° 41



Benefits

- Especially versatile since it is independent of the workpiece diameter
- Marking is possible at high speed
- Change of the reading direction is possible (see operating manual)

Application

- Precise positioning of characters on workpiece circumference
- Centre height corresponds to the first marking point
- Marking positions can be set as desired

Features

- The design of marking roll n° 41 is independent of the workpiece diameter
- Three driving points guarantee a perfect impression. They may be placed to the side of the characters
- Full depth and definition are accomplished in one go
- All characters can be used as a drive, e.g. logos, backlash, asterisks, number signs, etc.

Standard design		For marking tools
Flank angle	90°	421
Dimensions (Ø x width x bore) [mm]	25 x 6 x 6	
Typeface	According to DIN 1451	
Max. character height	See "Technology" starting on page 20	

Tool set 421



Product features

- Modular design:
Tool can be used as right-hand and left-hand version
- Modular shank design:
shank size 16 x 16 mm, adaptable
- Top edge of shank = centre height
- Set screws in shank for correcting alignment
- Hardened pin
- Right spring (pre-mounted) for spindle direction M3 (CW), see page 27

Set consisting of

- 1 x base shank (solid shank version) tool 421-16M
- 1 x shank adapter 20 x 20 mm
- 1 x shank adapter 25 x 25 mm
- 1 x spring, left (for changing the direction of rotation)
- In high-quality case

TOOL SET

Order no.	Tool holder designation	Dimension [mm]							
		a	b	c	d	e	f	x	
31002844	421-16M250606	16	16	112.5	25	32.5	28.5	2.5	
	With shank adapter 20 x 20 mm	20	20	112.5	25	32.5	32.5	2.5	
	With shank adapter 25 x 25 mm	25	25	112.5	25	32.5	37.5	2.5	

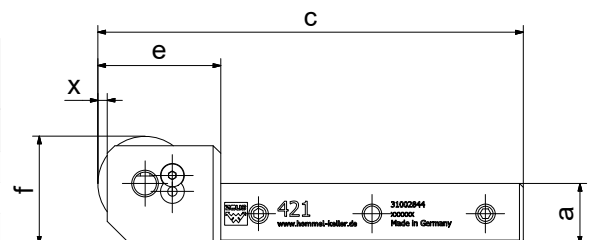

E-KIT

Order no.	Direction	
21BHR1503	right	
21BHR1504	left	

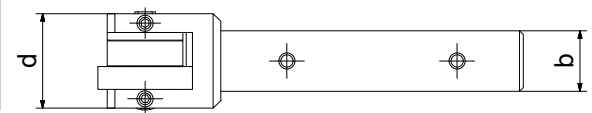

Marking roll n° 41



Benefits

- Especially versatile since it is independent of the workpiece diameter
- Marking is possible at high speed

Features

- The design of marking roll n° 41 is independent of the workpiece diameter
- Three driving points guarantee a perfect impression. They may be placed to the side of the characters
- Full depth and definition are accomplished in one go
- All characters can be used as a drive, e.g. logos, backlash, asterisks, number signs, etc.

Application

- Precise positioning of characters on workpiece circumference
- Centre height corresponds to first marking point
- Marking positions can be set as desired
- Possible to mark workpieces up to a shoulder

Standard design		For marking tools
Flank angle	90°	422
Dimensions (Ø x width x bore) [mm]	15 x 5 x 6 15 x 7 x 6	
Typeface	According to DIN 1451	
Max. character height	See "Technology" starting on page 20	

Tool set 422



Product features

- Modular shank design: shank size 8 x 8 mm, adaptable
- Top edge of shank = centre height
- Set screws in shank for correcting alignment
- Possible to mark workpieces up to a shoulder (for 15 x 7 x 6 mm marking roll)
- Hardened pin
- Right spring (pre-mounted) for spindle direction M3 (CW), see page 27

Set consisting of

- 1 x base shank (solid shaft version) tool 422-08R
- 1 x shank adapter 10 x 10 mm
- 1 x shank adapter 12 x 12 mm
- 1 x shank adapter 16 x 16 mm
- In high-quality case

TOOL SET

Order no.	Tool holder designation	Dimension [mm]						
		a	b	c	d	e	f	x
31002843	422-08R150506-A	8	8	101	24	21	16	1
	With shank adapter 10 x 10 mm	12	12	101	24	21	18	1
	With shank adapter 12 x 12 mm	12	12	101	24	21	20	1
	With shank adapter 16 x 16 mm	16	16	101	24	21	24	1

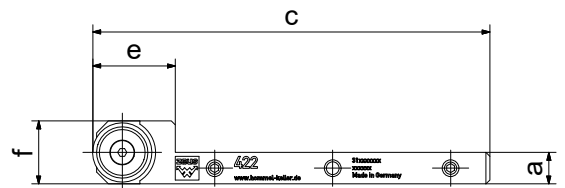

E-KIT

Order no.	Direction	
21BHR1505	right	

Set and E-kit also available in l/h version on request

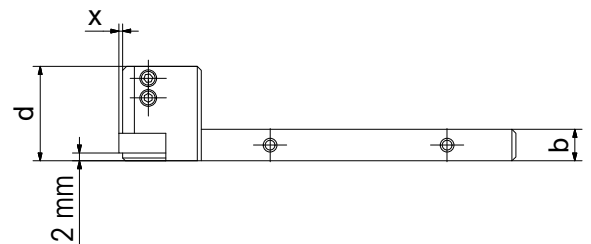

TOOL SET UP TO A SHOULDER

Order no.	Tool holder designation	Dimension [mm]						
		a	b	c	d	e	f	x
31002846	422-08R150706	8	8	101	24.5	21	16	1
	With shank adapter 10 x 10 mm	10	10	101	24.5	21	18	1
	With shank adapter 12 x 12 mm	12	12	101	24.5	21	20	1
	With shank adapter 16 x 16 mm	16	16	101	24.5	21	24	1

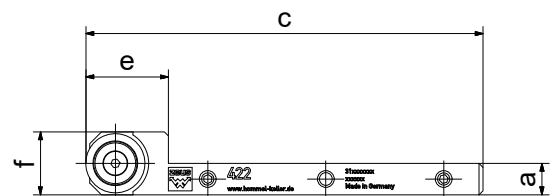

E-KIT

Order no.	Direction	
21BHR1507	right	

Set and E-kit also available in l/h version on request

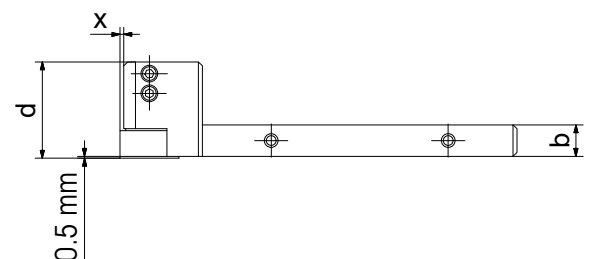

Marking segment n° 42



Benefits

- Especially versatile, since it is independent of the workpiece diameter
- Exchangeable segments enable fast, flexible, and economical adaptation of the text for different applications
- Marking is possible at high speed
- Change of the reading direction is possible (see operating manual)
- Exchangeable segment mount unit for faster switching to a different text
- Segments can be exchanged individually
- Full depth and definition are accomplished in one go
- All characters can be used as a drive, e.g. logos, backlash, asterisks, number signs, etc.

Application

- Precise positioning of characters on workpiece circumference
- Centre height corresponds to first marking point
- Marking positions can be set as desired

Features

- The design of marking segment n° 42 is independent of the workpiece diameter
- Three driving points guarantee a perfect impression. They may be placed to the side of the characters
- Marking without driving points is generally possible

Standard design		For marking tools
Flank angle	90°	431
Dimensions (Ø x width x bore) [mm]	45 x 6 x 33	
Typeface	According to DIN 1451	
Max. character height	See "Technology" starting on page 20	

Order no. character height 2 mm	Order no. character height 3 mm	Segments designation
8200067		Start segment
82002237	82002300	Letter set A-Z
82000441	82000378	Numeral set 0-9
82000433	82000041	Special character . (dot)
82000879	82002230	Special character/(slash)
82000416	82000040	Special character - (minus)
8200065		End segment

Tool set 431



Product features

- Modular design:
Tool can be used as right-hand and left-hand version
- Modular shank design:
shank size 16 x 16 mm, adaptable
- Top edge of shank = centre height
- Set screws in shank for correcting alignment
- Hardened pin
- Right spring (pre-mounted) for spindle direction M3 (CW), see page 27

Set consisting of

- 1 x base shank (solid shank version) tool 431-16M
- 1 x shank adapter 20 x 20 mm
- 1 x shank adapter 25 x 25 mm
- 1 x spring, left (for changing the direction of rotation)
- 1 x start and end segment
- In high-quality case

TOOL SET

Order no.	Tool holder designation	Dimension [mm]						
		a	b	c	d	e	f	x
31002845	431-16M450633-A	16	16	130.5	30	50.5	45	2
	With shank adapter 20 x 20 mm	20	20	130.5	20	50.5	45	2
	With shank adapter 25 x 25 mm	25	25	130.5	20	50.5	47.5	2

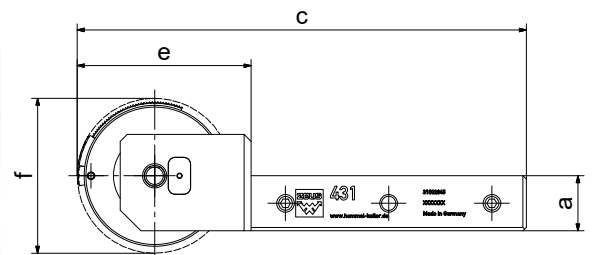

E-KIT

Order no.	Direction	
21BHR1509	right	
21BHR1510	left	

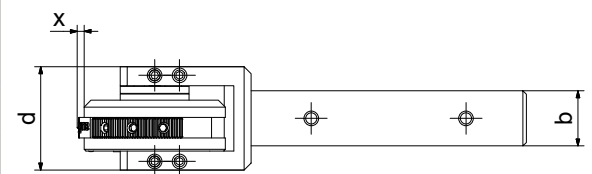

Marking segment n° 43



Standard design		For marking tools
Flank angle	90°	432
Dimensions (Ø x width x bore) [mm]	30 x 8 x 18 50 x 8 x 38	
Typeface	According to DIN 1451	
Max. character height	See "Technology" starting on page 20	

Benefits

- Especially versatile, since it is independent of the workpiece diameter
- Exchangeable segments enable fast, flexible, and economical adaptation of the text for different applications
- Marking is possible at high speed
- Reading direction can be changed by turning the T-shaped segments
- Possible to mark workpieces up to a shoulder
- Exchangeable segment mount unit for faster switching to a different text

Features

- The design of marking segment n° 43 is independent of the workpiece diameter
- Three driving points guarantee a perfect impression. They may be placed to the side of the characters
- Marking without driving points is generally possible
- Segments can be exchanged individually
- Full depth and definition are accomplished in one go
- All characters can be used as a drive, e.g. logos, backlash, asterisks, number signs, etc.

Application

- Precise positioning of characters on workpiece circumference
- Centre height corresponds to first marking point
- Marking positions can be set as desired

SEGMENTS Ø 30

Order no. character height 2 mm	Order no. character height 3 mm	Segments designation
85000000		Start segment
85001018	85001139	Letter set A–Z
85000991	85000621	Numeral set 0–9
85001019	85002485	Special character . (dot)
85001059	85001537	Special character / (slash)
85001654	85001257	Special character – (minus)
85000003		End segment

SEGMENTS Ø 50

Order no. character height 2 mm	Order no. character height 3 mm	Segments designation
85000113		Start segment
85001819	85001283	Letter set A–Z
85001431	85000476	Numeral set 0–9
85002486	85002487	Special character . (dot)
85001857	85001131	Special character / (slash)
85001912	85001600	Special character – (minus)
85000114		End segment

Tool set 432



Product features

- Modular shank design: shank size 8 x 8 mm and 16 x 16 mm, adaptable
- Top edge of shank = centre height
- Set screws in shank for correcting alignment
- Hardened pin
- Right spring (pre-mounted) for spindle direction M3 (CW), see page 27

Set consisting of

Tool 432-08R

- 1 x base shank (solid shank version) tool 432-08R
- 1 x shank adapter 10 x 10 mm
- 1 x shank adapter 12 x 12 mm
- 1 x shank adapter 16 x 16 mm
- 1 x start and end segment
- In high-quality case

Tool 432-16R

- 1 x base shank (solid shank version) tool 432-16R
- 1 x shank adapter 20 x 20 mm
- 1 x shank adapter 25 x 25 mm
- 1 x start and end segment
- In high-quality case

TOOL SET

Order no.	Tool holder designation	Dimension [mm]						
		a	b	c	d	e	f	x
31002833	432-08R300818	8	8	113.5	31.5	33.5	30	1
	With shank adapter 10 x 10 mm	10	10	113.5	31.5	33.5	30	1
	With shank adapter 12 x 12 mm	12	12	113.5	31.5	33.5	30	1
	With shank adapter 16 x 16 mm	16	16	113.5	31.5	33.5	31	1

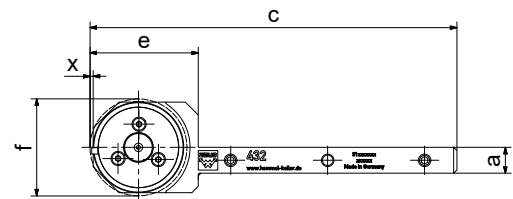

E-KIT

Order no.	Direction	
21BHR1081	right	

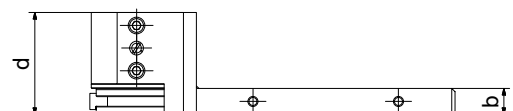

Set and E-kit also available in l/h version on request

TOOL SET

Order no.	Tool holder designation	Dimension [mm]						
		a	b	c	d	e	f	x
31002849	432-16R500838	16	16	138.5	31.5	58.5	50	1
	With shank adapter 20 x 20 mm	20	20	138.5	31.5	58.5	50	1
	With shank adapter 25 x 25 mm	25	25	138.5	31.5	58.5	50	1

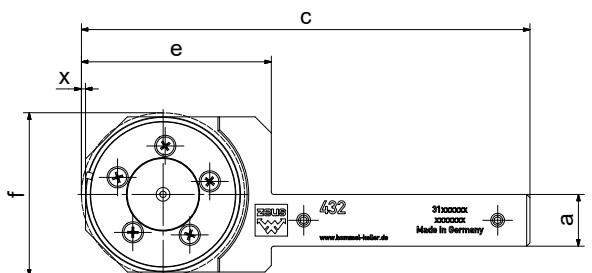

E-KIT

Order no.	Direction	
21BHR1111	right	

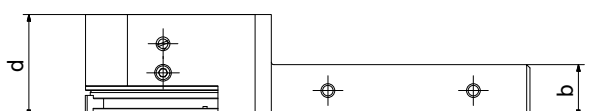

Set and E-kit also available in l/h version on request

Engraving technology

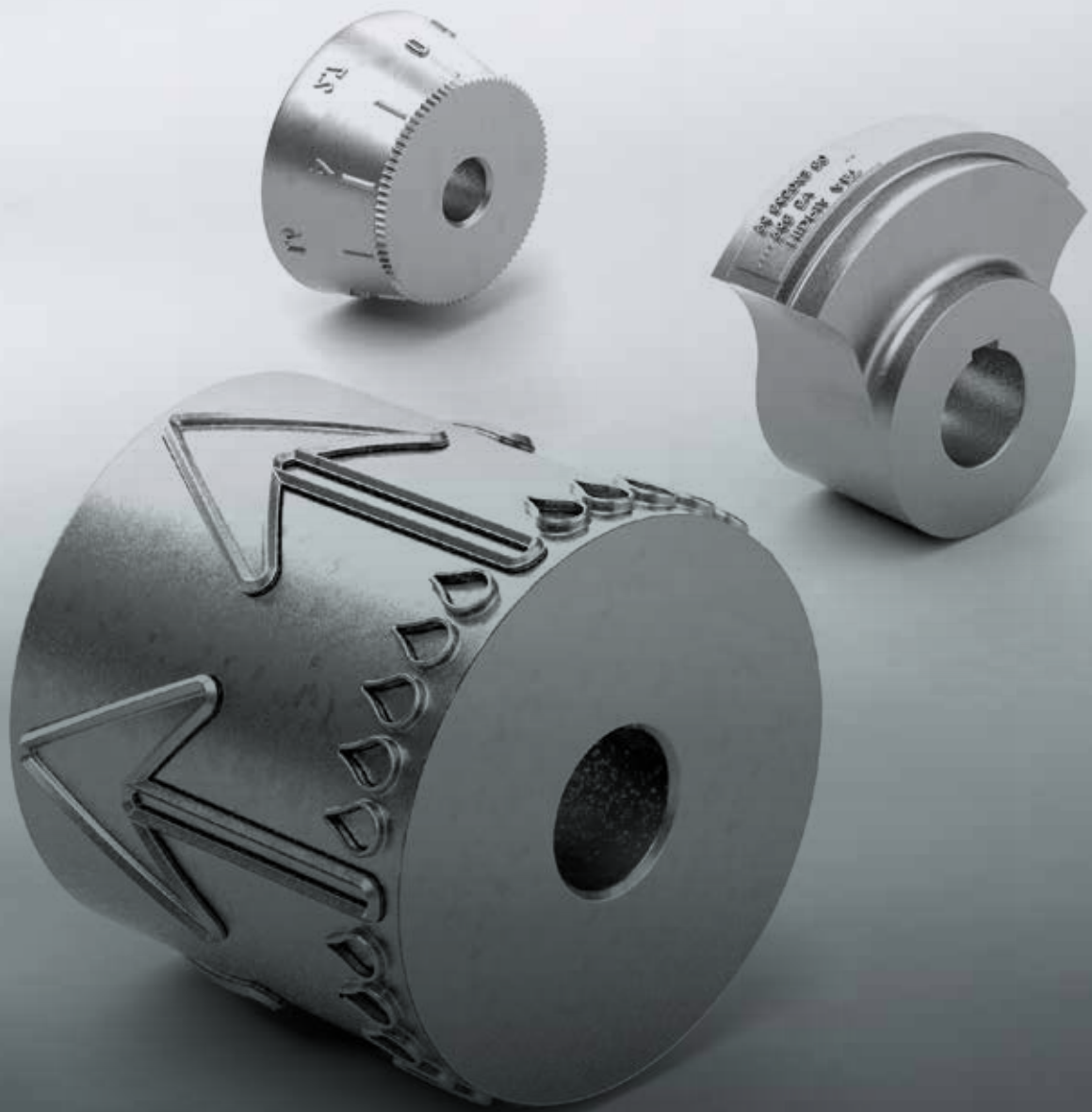

Rolls | embossing drums



Marking rolls

- Marking optionally with raised or recessed lettering

Embossing drums

- Embossing and printing of various materials, such as leather and textiles
- Marking optionally with raised or recessed lettering

Stamps



Hand stamps

- Marking of various materials for identification, numbering or decoration
- Your individual logos and symbols are manufactured exactly to your specifications

Machine stamps

- Embossing of all types of materials
- Shank end suitable for journal, groove or square holder
- Production is based on your requirements and drawings

Special engraving

- For marking of complex surfaces we will be glad to develop an individual solution. Based on your data and drawings we will develop and deliver the right tool, also for exceptionally complex applications

Technology

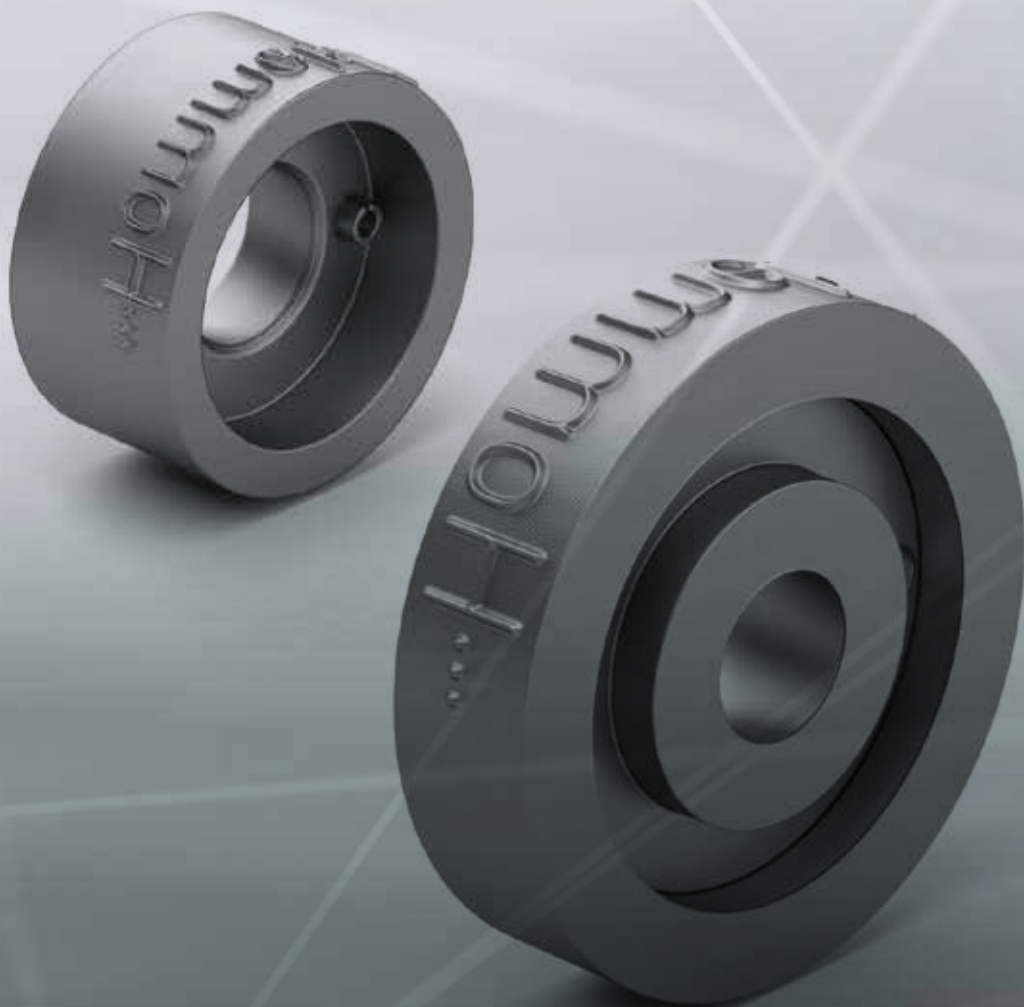

Visit www.hommel-keller.de for
video clips about marking technology.
Our marking tools will convince you!

Important information



Guidelines for process parameters

System	Material	Workpiece Ø	Speed n [rpm]	Feed rate, radial f [mm/U]	Impression depth (PT) a _p value [mm]*
Revolving	up to max. R _m = 1000 N/mm ²	Any	200	0.08	r = 0.075 Ø = 0.15
Spring-return	up to max. R _m = 1000 N/mm ²	Any	200 Unwinding via C-axis is possible	f = d x π (d = workpiece diameter) High speed (possible with restrictions)	r = 0.075 Ø = 0.15



The values provided here are recommendations (base values) and must be optimised for the application.

* The impression depth must always be greater than the concentricity (Ø 0.03 mm).

The embossing quality and the wear of the marking rolls/segments is dependent on:

- the combination of workpiece diameter and speed
- the feed rate
- the material
- and the application (e.g. clamping set-up – single- or double-sided)

Surfaces for marking must be clean (free of surface contaminants) to ensure optimal driving of the segments and the marking roll. When marking in axial direction – spindle stop (speed = 0), feed rate in axial direction = feed rate in radial direction.

Spring-return system – start-up when stopped

1. Spindle at standstill
2. Infeed of tool to desired impression depth
3. Run spindle slowly
4. Return of tool

Explanation of tool holder designation

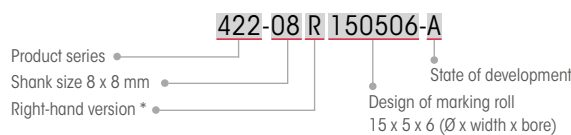

* L = 1/h design
M = modular design

Explanation of marking roll designation

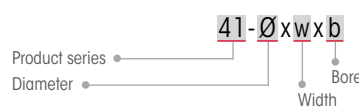

Shank adapter

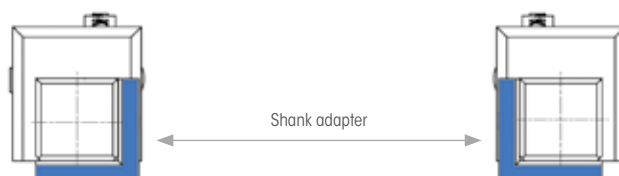

With the modular tool sets 421 and 431 the adapter is used to change the shank size asymmetrically.

Marking roll specifications

1. Typefaces

- The standard typeface is based on DIN 1451 (Other typefaces available on request)
- A .dxf file is needed for logos and special characters

2. Possible marking types | drives

- To ensure continuous rotation of the tool, a drive is needed, which can be custom designed (logo, backlash, asterisks, number signs, etc.) and removed by means of reworking (cutting off, finish machining, bevelling, etc.)

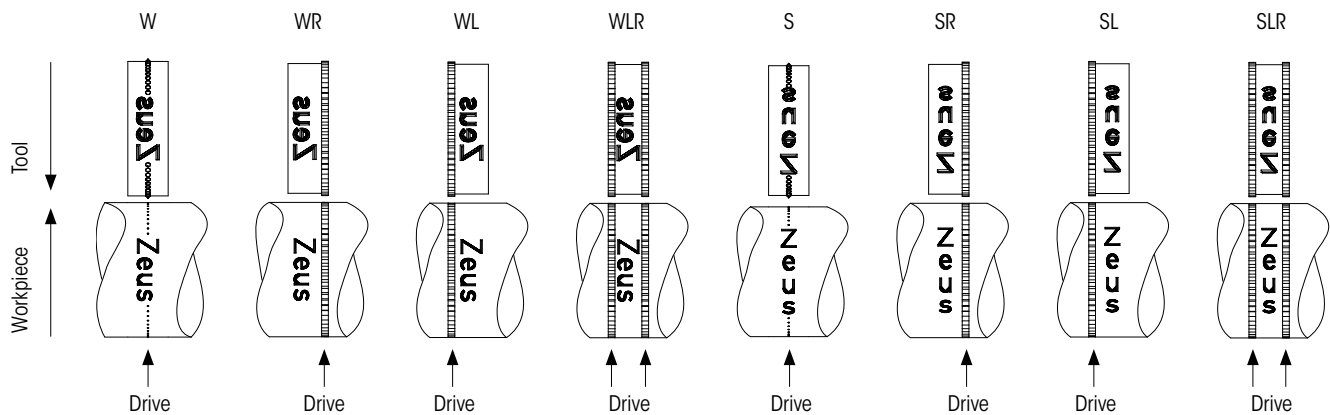

3. Character height/ embossing depth

- The standard flank angle is 90° (Other flank angles available on request)
- Minimum character height: 0.8 mm
- Maximum character height: Depending on the roll width all standard sizes are possible
- The character height is measured on the offset (see figure below)
- Standard embossing depth: 0.35 mm

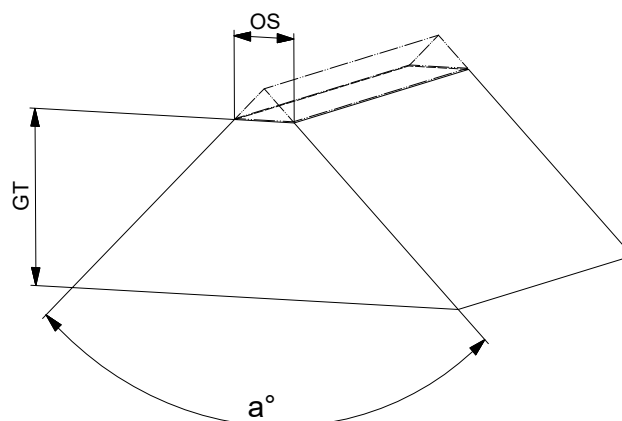
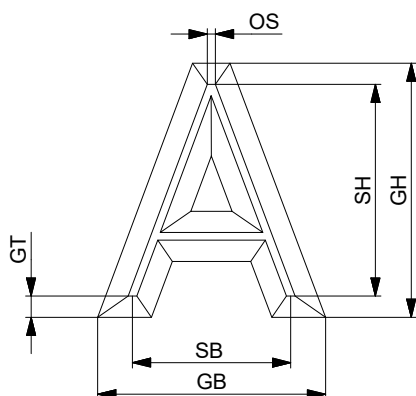

- a° = flank angle
- GT = embossing depth
- GB = embossing width
- GH = embossing height
- SB = character width
- SH = character height
- OS = offset

4. Diameter ratio: Marking roll – workpiece

- The diameter of the marking roll is dependent on the workpiece diameter

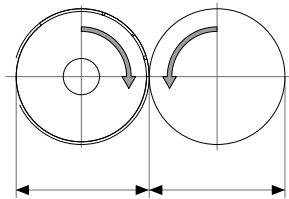

Marking roll \varnothing : Workpiece \varnothing
 $i = 1 : 1$

$i = 1$

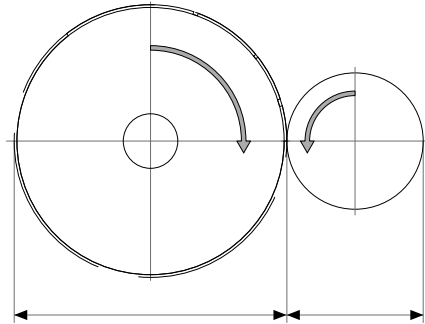

Marking roll \varnothing : Workpiece \varnothing
 $i = n : 1$

$i > 1$

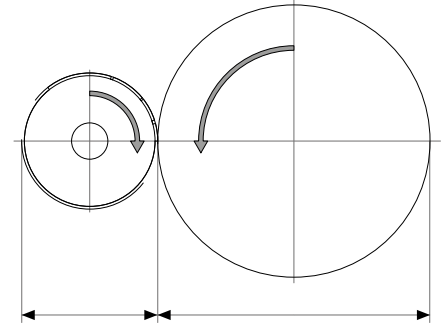

Marking roll \varnothing : Workpiece \varnothing
 $i = 1 : n$

$i < 1$

Practical guidance

1. Preparation of workpiece

- The surface must be clean
- Perfect concentricity is essential (0.03 mm)
- The diameter of the workpiece must be very precise (max. tolerance: ± 0.025 mm)

2. Impression depth

- The standard impression depth is 0.075 mm relative to the radius/ 0.15 mm relative to the diameter
- Impression depths exceeding the recommended maximum values may cause character distortions

3. Marking as part of the machining process

- The position of the drive on the workpiece should be taken into account during the machining process
- There is a danger that weak parts of the workpiece are deformed during marking.
We recommend marking to be carried out on the strong parts of the workpiece and/or before the critical machining steps

Specification of the marking roll/segments

1. Typefaces

- The standard typeface is based on DIN 1451 (Other typefaces available on request)
- A .dxf file is needed for logos and special characters

2. Possible marking types | drives

- In the standard version the drive is positioned on the centre of the marking roll/marking segment
- On request, the drive, which can be custom designed (logo, backslash, asterisks, number signs, etc.), can be applied to the side of the characters and removed afterwards by reworking (cutting off, finish machining, bevelling, etc.)

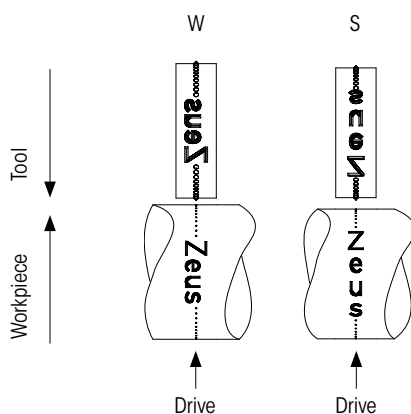

3. Character height/ embossing depth

- The standard flank angle is 90° (Other flank angles available on request)
- Minimum character height: 0.8 mm
- Maximum character height: Segment width - 1 mm (Example: max. character height = 6 mm - 1 mm = 5 mm)
- The character height is measured on the offset (see figure below)
- Standard embossing depth: 0.35 mm

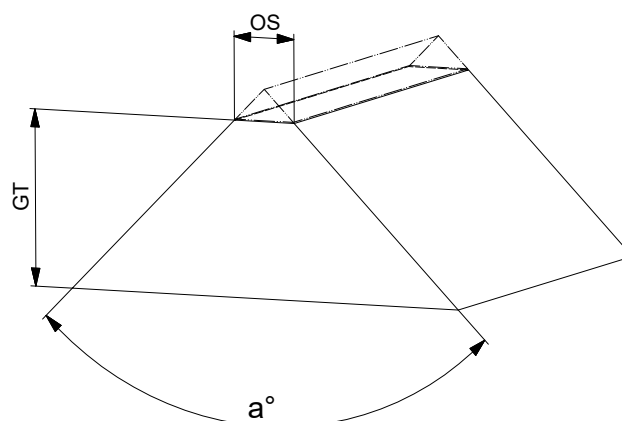
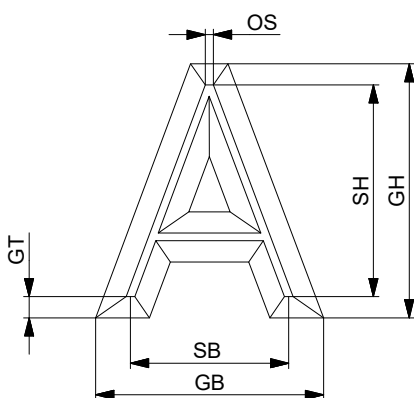

- α° = flank angle
- GT = embossing depth
- GB = embossing width
- GH = embossing height
- SB = character width
- SH = character height
- OS = offset

4. Diameter ratio: Roll/segments – workpiece

- The diameter of the marking roll/segments is **independent** of the workpiece diameter

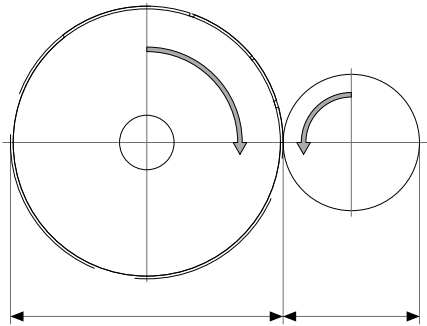

Marking segment \emptyset :
 $i = n : m$

Practical guidance

1. Preparation of workpiece

- The surface must be clean
- Perfect concentricity is essential (0.03 mm)

2. Impression depth

- The standard impression depth is 0.075 mm relative to the radius/
0.15 mm relative to the diameter
- Impression depths exceeding the recommended maximum values
may cause character distortions

3. Marking as part of the machining process

- The position of the drive on the workpiece should be taken into account
during the machining process
- There is a danger that weak parts of the workpiece are deformed
during marking. We recommend marking to be carried out on the strong
parts of the workpiece and/or before the critical machining steps

In-quiry

This form is available for download at www.hommel-keller.de

Caution: For implementation of a logo or special character we reserve the right to add an extra charge to the invoice. Please provide us with the corresponding .dxf file.

Company _____

Post Code, City _____

Contact person _____

Tel./email _____

Number of marking rolls _____

Application Cylindrical roll Tapered roll

Tool
Workpiece

Workpiece diameter _____ Width of marking roll _____ Bore of marking roll _____

Logo

Text

1. Line: _____

2. Line: _____

3. Line: _____

Character height _____ Typeface DIN 1451 Other _____

Drive

Pitch: _____ Standard 0.8 mm

Width: _____ Standard 1.0 mm

If no specifications are provided for the drive, we will use the Hommel+Keller standard.

Tool holder Yes No Tool Version Right Left

Number of tool holders _____ Shank size _____

Comment

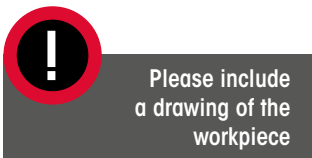

zeus – a brand of Hommel+Keller

Hommel+Keller
 Präzisionswerkzeuge GmbH
 78554 Aldingen · Germany
 Tel. +49 7424 9705-0
 info@hommel-keller.de
www.hommel-keller.de



zeus – a brand of
Hommel+Keller



PRÄZISIONSWERKZEUGE

Hommel+Keller

Präzisionswerkzeuge GmbH

78554 Aldingen · Germany

Tel. +49 7424 9705-0

info@hommel-keller.de

www.hommel-keller.de